

# SNOWDOGG® LIGHT REFERENCE

G2 (2017+) HARNESS

STANDARD AND GROUND SWITCHED APPLICATIONS



---

## SNOWDOGG LIGHT REFERENCE

GENERAL REFERENCE	3
TROUBLESHOOTING GUIDES/PROCEDURES	6
CONNECTOR REFERENCE	12
ADAPTER HARNESS REFERENCE (1607****)	13
SCHEMATIC REFERENCE	23

### Welcome

This manual is intended to aid in a better understanding of how the SnowDogg headlight circuit operates for use in troubleshooting. It is often much faster to replace a harness than it is to do extensive troubleshooting.

In new installations, MOST light malfunctions are due to installation errors or the wrong adapter. Before beginning any extensive troubleshooting, double check the application and installation and check the [www.snowdoggplovs.com](http://www.snowdoggplovs.com) website for updated installation instructions and technical service bulletins.

Contact your dealer promptly for technical assistance – all lighting issues can usually be resolved very quickly, and those that cannot are usually due to an issue with the vehicle side circuit.

Always verify that ALL light circuits on the vehicle are working properly before beginning plow installation. Aftermarket accessories like Remote Starters, HID kits, non-factory headlights, existing plow installations, can cause an installation to fail. It may be necessary to remove aftermarket components to ensure the proper operation of the plow lights.

TIP: The SnowDogg lighting circuit is complete separately from the controller circuit. Any references to wire colors are specific to the relay harness. The plow controller does not need to be installed or powered for normal light operation.

With any troubleshooting it is easiest to reduce the normal of components being checked at any one time. The G2 relay module should work normally without headlight adapters connected as it has an independent ground. This will allow you to connect the A or B headlights separately.

## METHOD OF OPERATION

---

### What is different between G1 and G2 harnesses?

The G2 harness is split into a relay module (16160100) and grill connector harness (16160102) to make installation easier. The functionality is the same. The G2 relay harness set works identically to the G1 harness and is fully backwards compatible with all SnowDogg plows. The only differences are in how it is connected to power and ground.

	G1 - 16160100	G2 - 16160102/16160104
GROUND	WHITE/BLACK - from 16160300 control harness BLACK wire	Dedicated ring terminal for independent ground
POWER (+12VDC Ignition Switched)	ORANGE WIRE - from 16160300 control harness RED/WHITE wire	ORANGE WIRE - from 16160302 control harness RED/WHITE wire

### Standard vs Switched Ground

What is "Standard Switched" and "Switched Ground"?

Most trucks are "Standard Switched". This refers to controlling a circuit by sending power to it through a switch - much like a light switch in your home. Some trucks are "Switched Ground" which means the lights have power to them all the time, and they are controlled by connecting them to ground (through a switch). Both methods have the same result - but as the plow is designed for standard switched vehicles, switched ground requires changes to the installation and sometimes specific headlight adapters.

**ALWAYS CHECK THE APPLICATION GUIDE.** A standard install on a switched ground truck will not work.

### Method of Operation for STANDARD SWITCHED VEHICLES

#### Installation

The 16160102 relay module installation for standard switched vehicles requires:

- Proper grounding of the BLACK ground wire w/ring terminal
- Connection of the ORANGE wire to the RED/WHITE wire from the 16160302 control harness.  
Alternately, any fused, 15A ignition switched source may be used in place of the RED/WHITE wire

#### Headlights

The SnowDogg relay module (16160102) diverts power for the plow high and low beams from the truck headlight circuit to the snowplow lights when the plow is connected and the ORANGE wire is energized (connected to ignition switched power through the RED/WHITE wire from the control harness). Connecting the plow completes the ground circuit for the 4 headlight relay coils, causing them to shift, diverting power to the plow lights through the grill connector harness (16160104). The relay ground circuit starts at the headlight relay coils, goes out through the grill connector, to the plow, back through the grill connector, and into a dedicated ground for the relay module. This connection can be simulated by connecting pins A+H on the relay module or grill connector for troubleshooting purposes.

When the plow is disconnected the ground circuit is broken, and the relays de-energize, allowing power to flow through the relay common to normally closed contacts to the truck headlights. In this situation – the truck lights should behave identically to how they behave without the adapter installed.

If the orange wire is disconnected or loses power, the relays will also de-energize. The turn signals will also not work on the plow if Orange is disconnected.

**NOTE:** If the orange or red/white wire is hooked straight to a battery +12V, it will draw current at all times, draining the battery. Per the installation instructions, an ignition switched source must be found.

#### Turn Signals

The purple turn signal wires in the headlight adapters (1607\*\*\*\*) are tee'd in to the truck turn signal circuit, and are ONLY used to energize the turn signal relay coils, which draw minimal current, and should not disrupt the truck lighting circuit.

## METHOD OF OPERATION

---

The actual plow turn signal bulbs are powered by the orange wire (connected to the red/white wire) and are grounded with the headlights. The turn signal relays are grounded through the dedicated ground for the relay module (Black wire).

### Parking Lights

The plow parking lights are tapped directly into the truck parking light circuit and are not isolated through relays. The brown wire that taps into the vehicle parking light wire is directly connected to the plow parking light. It is grounded through the dedicated relay module ground. This is an excellent place to start when troubleshooting.

**TIP:** Any applications using 16160800 LED plow lights should connect the parking wire (BROWN) to ignition switched power to prevent current overdraw when the lens heaters activate.

## METHOD OF OPERATION

---

### Method of Operation for GROUND SWITCHED VEHICLES

#### Installation

The 16160102 relay module installation for switched ground requires the following:

- Proper grounding of the BLACK ground wire w/ring terminal
  - Disconnect the BLACK/WHITE wire terminals (often tucked inside the loom in the 16160104 grill harness).
  - Connect the BLACK/WHITE wire running to the grill (plug) to the RED/WHITE wire from 16160302 control harness  
Alternately, any fused, 15A ignition switched source may be used in place of the RED/WHITE wire.
  - Connect the BLACK/WHITE wire running into the relay module (socket) to the ORANGE wire
- TIP: For switched ground trucks, 16160800 LED headlights with a G2 harness will require a 16071310 headlight isolation kit. For G1 plows, contact SnowDogg Tech Support.

#### Headlights

The SnowDogg relay module diverts the switched ground signal for the high and low beams from the truck headlight circuit to the snowplow lights when the plow is connected and the Black/White wire going to the grill connector is energized when connected to the Red/White wire from the control harness. Connecting the plow completes the power circuit for the headlight relays, causing them to shift, connecting the vehicle ground to the plow headlight bulb. In a switched ground vehicle, the common circuit is +12V.

When the plow is disconnected or the white/black or gray wire is not powered, the power circuit is broken, and the headlight ground signal is connected through the relay common to normally closed contacts to the truck headlights.

TIP: If the gray or red/white wire is hooked straight to a battery +12V, it will draw current at all times, draining the battery. Per the installation instructions, and ignition switched source must be found.

#### Turn Signals

## METHOD OF OPERATION

---

The purple turn signal wires on the headlight adapters (1607\*\*\*\*) are tapped into the truck turn signal circuit and are ONLY used to energize the turn signal relays, which draw minimal current, and should not disrupt the truck lighting circuit. These relays connect the switched leg of the plow turn signals to ground when energized. The turn signal bulbs are powered by the +12V common (black wire at the plow headlights).

### Parking Lights

The brown wires for the plow parking lights are connected to vehicle ground – NOT TO THE VEHICLE PARKING CIRCUIT. The plow parking lights are powered by the +12V common (black wire at the plow headlights).

TIP: If the brown wires are incorrectly connected to the vehicle parking light circuit, they will only work when the vehicle is turned on, but the ignition is off. When the ignition is turned on, the plow parking lights will turn off.

## METHOD OF OPERATION

---

### NORMAL LIGHT OPERATION

#### Plow Parking lights

On simultaneously with the Truck Parking Lights. For SWITCHED GROUND vehicles the parking lights will be on whenever the vehicle ignition is on, regardless of the vehicle parking light status.

#### Plow Turn Signals

On simultaneously with the Truck Turn signals / isolated by relays

#### Plow Headlights

On INSTEAD of Truck headlights. Truck and Plow headlights should NEVER be on at the same time.

### HEADLIGHT ADAPTERS

#### Installation

Standard SnowDogg headlight adapters are installed between the vehicle headlight harness and the vehicle headlights. This may be at the headlight bulb itself, or in most modern trucks further back using an in-line connector. Some adapters will require splicing into the park and turn circuits, while some are "plug and play".

The adapter interrupts the power to the truck headlights and sends it to the 16160102 relay module where it is either diverted to the plow lights, or sent back through the adapter into the truck light circuit. There are often several "pass through" circuits on the adapter to ensure that the truck lights behave the same with or without the adapter installed.

Some newer vehicles like the RAM full size trucks have a relay harness that completely replaces the 16160102 and works differently, while other vehicles like the 2020+ Ford Superduty may require additional relays in the adapter to properly work with the truck.

## METHOD OF OPERATION

---

### TROUBLESHOOTING

MOST light malfunctions are due to installation problems. Before beginning any extensive troubleshooting, check the [www.snowdogglows.com](http://www.snowdogglows.com) website for updated installation instructions and technical service bulletins. Review the instructions for your specific application and verify that all instructions have been followed.

Contact your dealer promptly for technical assistance – all lighting issues can usually be resolved very quickly, and those that cannot are usually due to an issue with the vehicle side circuit.

Always verify that ALL light circuits on the vehicle are working properly before beginning plow installation. Aftermarket accessories like Remote Starters, HID kits, non-factory headlights, existing plow installations, can cause an installation to fail. It may be necessary to remove aftermarket components to ensure the proper operation of the plow lights.

Symptom	Cause	Resolution
Truck lights do not behave properly after plow is installed on truck	Headlight adapter or relay harness is incorrectly installed or faulty	Check installation
Plow lights deactivate when high beams are selected	Polarity on connection between headlight adapter and vehicle harness is reversed. Switched ground truck w/standard install.	Verify application Contact Tech Support
Parking lights turn off when plow headlights are activated	Brown wires on headlight adapters are connected to wrong location.	Standard vehicles – brown wire to parking circuit. Switched ground vehicles – brown wire to GROUND
Plow headlights are on at the same time as truck headlights	Headlight adapter or relay harness is incorrectly installed or faulty.	Check installation

## METHOD OF OPERATION

---

Plow lights do not activate when plow is connected	Ground circuit through headlight adapter is wrong.	Verify polarity of headlight adapters
	Orange wire is not at +12V	Check Installation
	A headlight relay coil is shorted/not operating	Replace faulty relay
Fuses blow when lights are activated	There is a short to ground in the circuit	Verify all harnesses and lights
	Vehicle draws excessive current (>10A)	Replace in-line fuse with 15A fuse
High and Low Beams are on at the same time	Truck has "dual burn" hi/low beams (2007+ GM)	Works as Designed – no issue.
Lights on one side of vehicle are behaving differently than other side (dim, off, etc.)	Headlight adapter harness is installed incorrectly	Verify installation or Replace
	Vehicle side fuse is blown	Check/Replace Fuses
Truck lights do not reactivate when plow is disconnected	Headlight adapter or relay harness is incorrectly installed or faulty	Check installation
A single light is not working (left low beam, right parking, etc.)	The bulb is defective	Replace
	A harness has an open circuit	Repair/Replace

## METHOD OF OPERATION

---

	If truck remains on – the relay controlling that bulb is malfunctioning	Replace
Parking lights and Turn signals do not operate on the plow when headlights are off	Headlight adapter or relay harness is incorrectly installed or faulty	Verify Installation
	Ambient light sensor is disabling power to plow lights	Verify Installation
Plow lights remain on when the truck is off	Installation is incorrect for the vehicle application	Verify Installation
Battery is being drained when truck is off	Red/White wire is not connected to a ignition switched circuit	Connect to a switched circuit
	Installation is incorrect	Verify Installation

## METHOD OF OPERATION

---

These instructions are written for STANDARD switched vehicles only. Contact technical support for assistance with GROUND switched vehicles.

### Relay Module Activation Troubleshooting

1. Disconnect the plow light harness from the truck light harness (unplug the large overmolded connector)
2. Turn the truck parking lights on
3. Check for continuity between pin A and GROUND
  - If there is continuity
    - Continue
  - If there is no continuity –
    - Ensure that BLACK ground wire on 16160102 relay module is properly grounded and ring terminal is crimped to wire (not insulation).
    - Check Grill Connector Harness (16160104) White/Black wire for damage/breaks
4. Check for +12V on pins G+J, using pin A as ground
  - If +12V IS present
    - Park lights on plow should functional normally
  - If +12V IS NOT present
    - One of the two brown wires has a continuity break and must be repaired
5. Measure resistance between pin H and the orange wire. It should be between 20 and 25 ohms.
  - If the resistance is nearly zero
    - A relay is defective and must be replaced. Remove each relay and check resistance across the coil to find the faulty relay.
  - If the resistance is within acceptable limits
    - Continue
6. Check for +12V on the RED/WHITE or ORANGE wire
  - If voltage is present
    - Contact SnowDogg tech support
  - If voltage is not present
    - Check the power supply to the orange wire – this should be connected to an ignition switched accessory circuit.

### Relay Module Headlight Circuit Troubleshooting

1. Turn on truck low beam headlights
2. Jumper pins A and H together – this will simulate the plow being connected  
You should hear the relays click at this point, and truck lights should turn off. If the relay module begins to buzz, than the ground circuit is faulty.
3. Check for +12V at pins B and D (Low Beams) on grill headlight connector
  - a. If +12V IS present
    - i. Continue
  - b. If +12V IS NOT present
    - i. Check for +12V at pin C of the adapter connector (YELLOW)
      1. If +12V IS present
        - a. The headlight adapter is defective or incorrect– repair/replace
      2. If +12V IS NOT present
        - a. The relay harness is faulty – repair/replace
4. Switch the truck lights to high beams
5. Check for +12V at pins C and E (High Beams)
6. If +12V IS present
  - i. Continue
7. If +12V IS NOT present
  - i. Check for +12V at pin F of the adapter connector (GREEN)
    1. If +12V IS present
      - a. The relay harness is defective – repair/replace
    2. If +12V IS NOT present
      - a. The headlight adapter is faulty – repair/replace

## METHOD OF OPERATION

---

### Turn Signal Troubleshooting

- 1) Activate left or right turn signal
- 2) Check for voltage at pins G and K – one should be pulsing with +12V (one is Left, one is Right)
  - If +12V IS present
    - Continue
  - If +12V IS NOT present
    - Check for pulsing +12V at purple wire at position H of appropriate adapter harness connector
    - If voltage is present
      - The relay harness is defective – repair/replace
    - If voltage is not present and vehicle turn signals work properly
      - Check the connection of the purple wire – it should be spliced into the vehicle turn signal wire.
- 3) Activate the right turn signal and repeat above

### Plow Light/Plow Light Harness Troubleshooting

- 1) Connect the Plow Light Harness to the Relay Harness.
- 2) Check operation of all lights
  - Headlight not functioning properly?
    - Disconnect both headlights – set aside working headlight
    - Connect faulty headlight to OTHER harness lead
    - Still faulty?
      - Headlight is defective – repair/replace
    - Works OK
      - Wiring harness is faulty –repair/replace

## METHOD OF OPERATION

---

### Power Draw Troubleshooting

- 1) Connect the Plow Light Harness to the Relay Harness and turn on vehicle.
- 2) Check for proper operation of all plow and truck lights
  - Working properly  
Continue
  - NOT working properly  
Lighting installation is incorrect – Review installation
- 3) Turn vehicle off
- 4) Connect Plow
  - If any lights on the plow are on  
Lighting installation is incorrect – Review installation
  - All lights off  
Continue
- 5) Install a clamp on ammeter on the main battery connection and measure current draw with the plow connected AND disconnected.
  - Draw is the same  
The issue is not related to the plow – STOP
  - Draw with plow connected is higher  
Continue
- 6) Place clamp on ammeter on Orange wire
  - If current draw is  $>0$ 
    - Disconnect Orange wire
    - Measure resistance between Orange wire and battery ground
      - If resistance is  $<20$  ohms  
Relay harness is faulty – repair/replace
      - If resistance is between 20 and 25 ohms  
Contact SnowDogg tech support
  - If current draw is 0  
Continue
- 7) Place clamp on ammeter on Red Wire
  - If current draw is  $>0$

## METHOD OF OPERATION

---

Disconnect red wire

Measure resistance between Red wire and battery ground

If resistance is <40 ohms

Relay Harness is faulty – repair/replace

If resistance is between 40-50 ohms

Disconnect Purple wires from vehicle turn signal wires on both sides of the vehicle

If current draw on Red wire is still >0

The Relay Harness is faulty – repair/replace

If current draw on Red wire is 0

Contact SnowDogg tech support

If current draw is 0

Continue

8) Disconnect Headlight Adapters (1607\*\*\*\*) on both sides of vehicle

If current draw is >0

Contact SnowDogg Tech Support

If current draw is 0

Headlight adapters are faulty – repair/replace

CONNECTOR PINOUTS

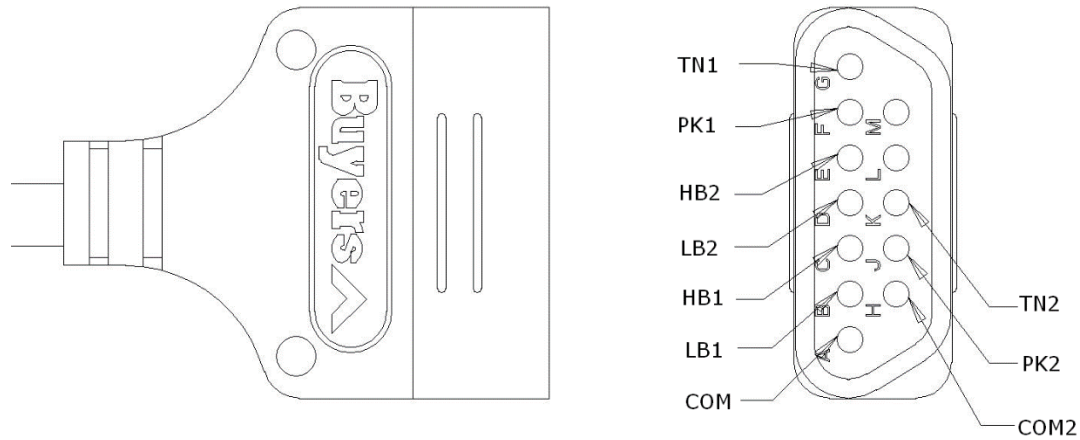

16160104 Grill Harness Connector to  
16160250 Light Harness  
TRUCK SIDE

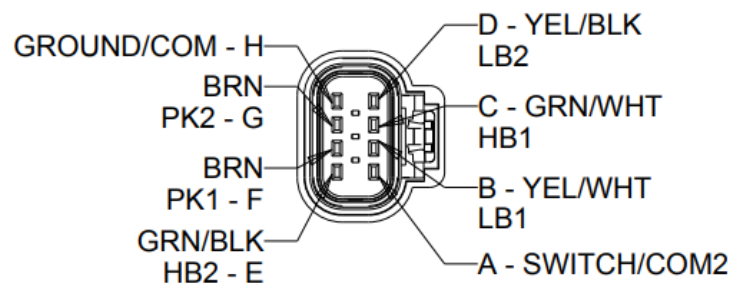

16160102 Relay Module Connector to  
16160104 Grill Harness  
RELAY MODULE SIDE

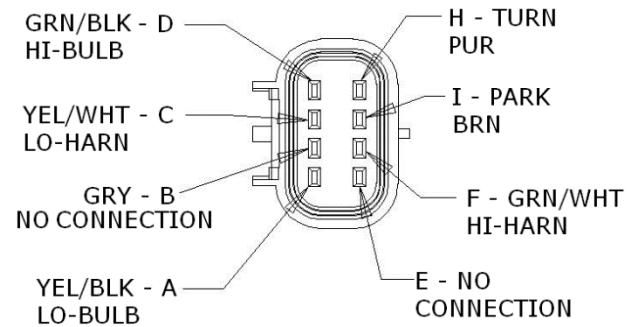

16160102 Relay Module Connector to  
1607XXXX Headlight Adapter  
RELAY MODULE SIDE

## 16071050 UNIVERSAL SPLICE KIT

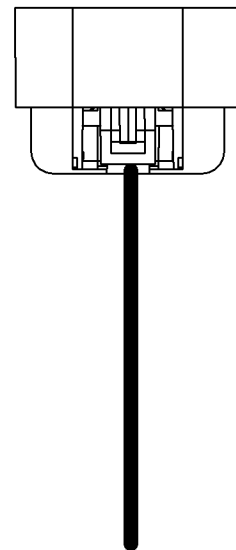
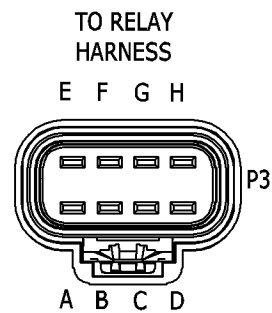

FUNCTION	P3 PIN	WIRE COLOR	RELAY HARNESS
LIGHT LB	A	YEL/BLK	YEL/BLK
COMMON	B	BLK	GRAY*
HARNESS LB	C	YEL	YEL/WHT
LIGHT HB	D	GRN/BLK	GRN/BLK
-	E	-	-
HARNESS HB	F	GRN	GRN/WHT
PARK	G	BROWN	BROWN
TURN	H	PURPLE	PURPLE

\* ONLY PRESENT ON SHORT  
RELAY HARNESS LEAD

16071100  
H13

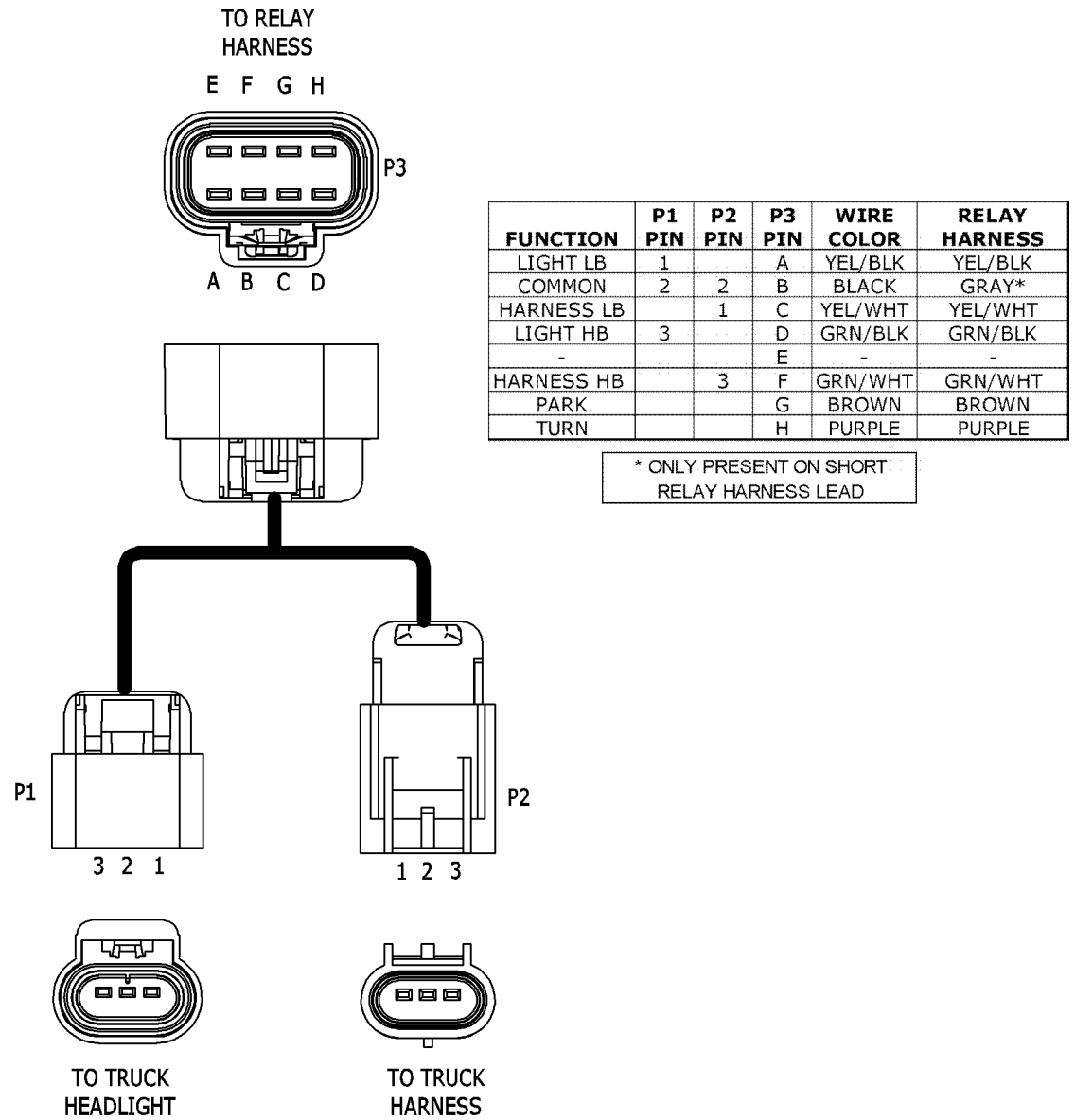

16071110  
GM 2007+ BREAKOUT

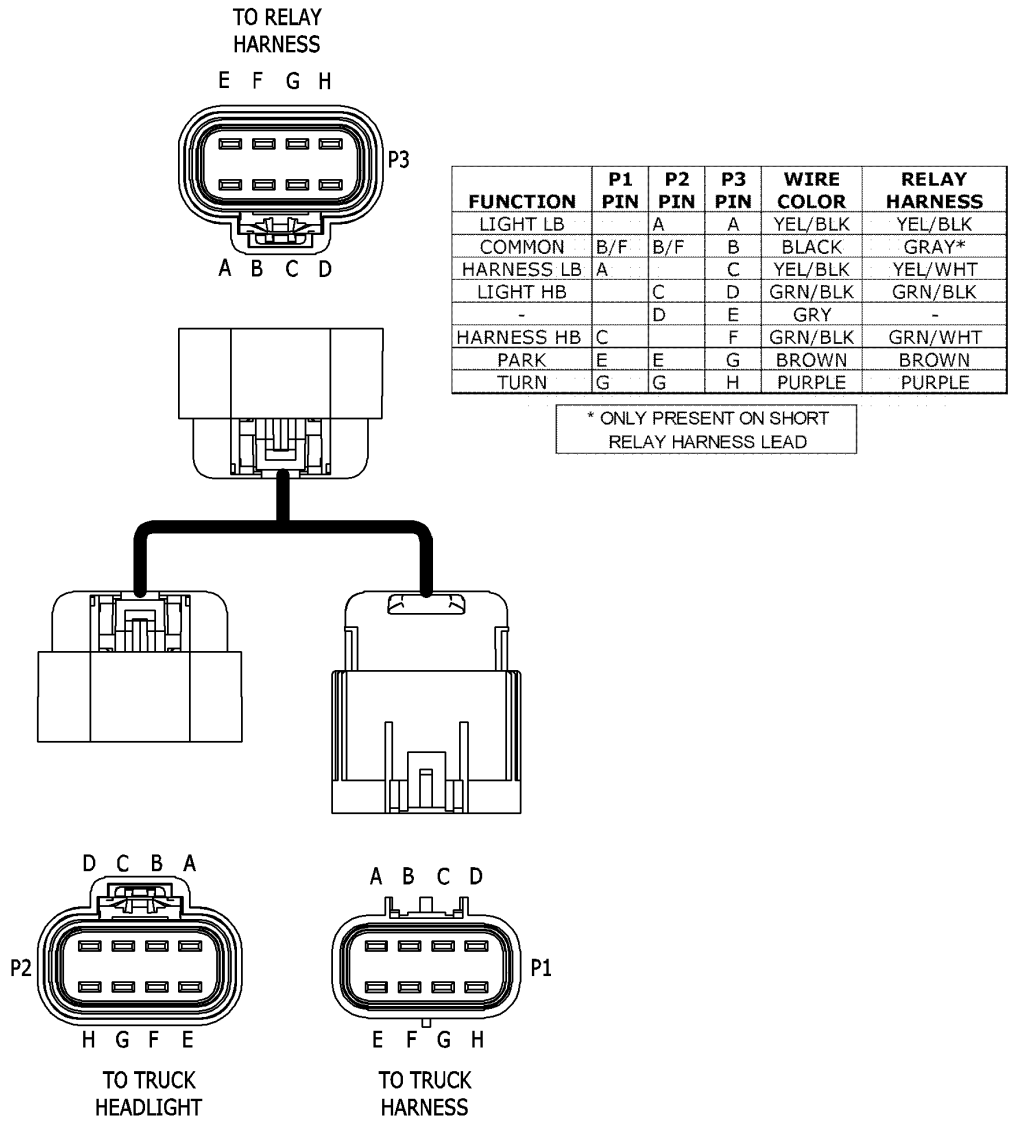

16071120  
HB5

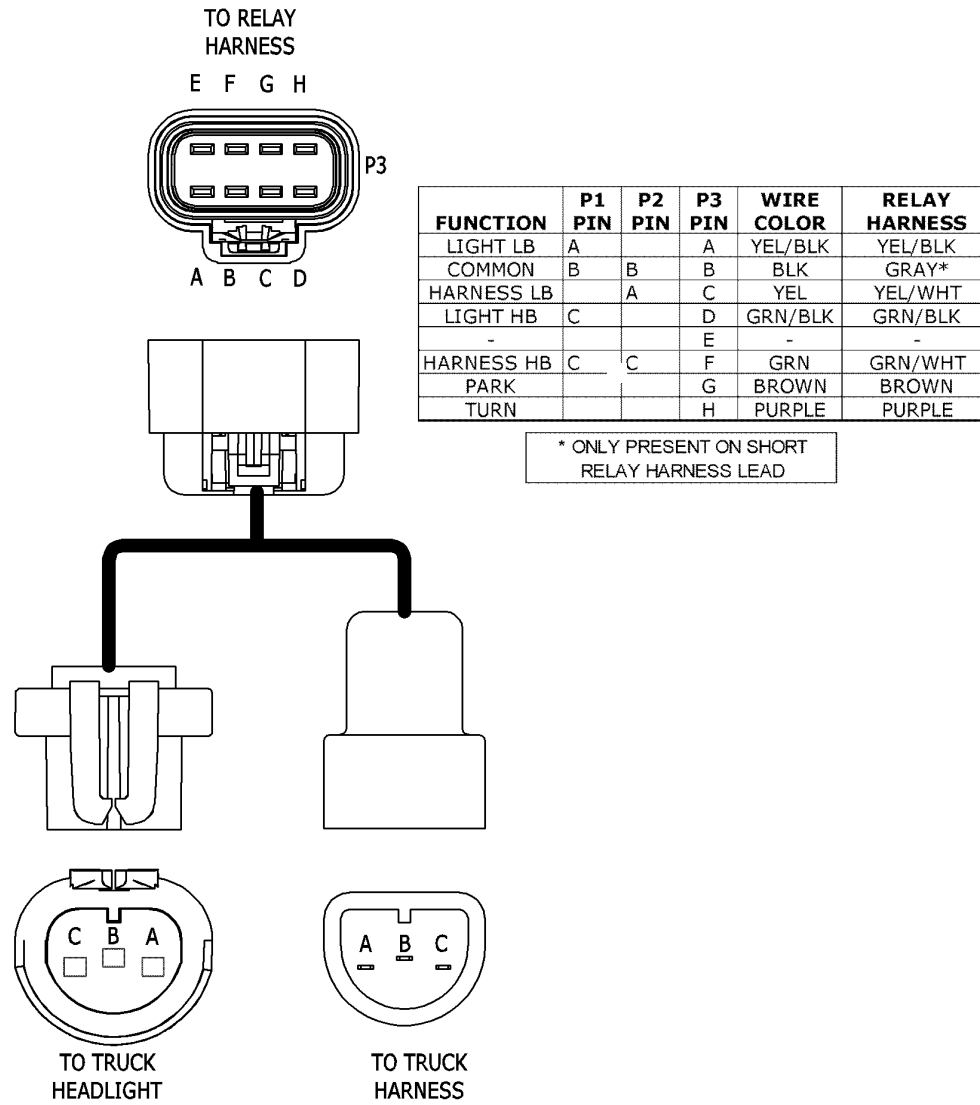

16071130  
HB1

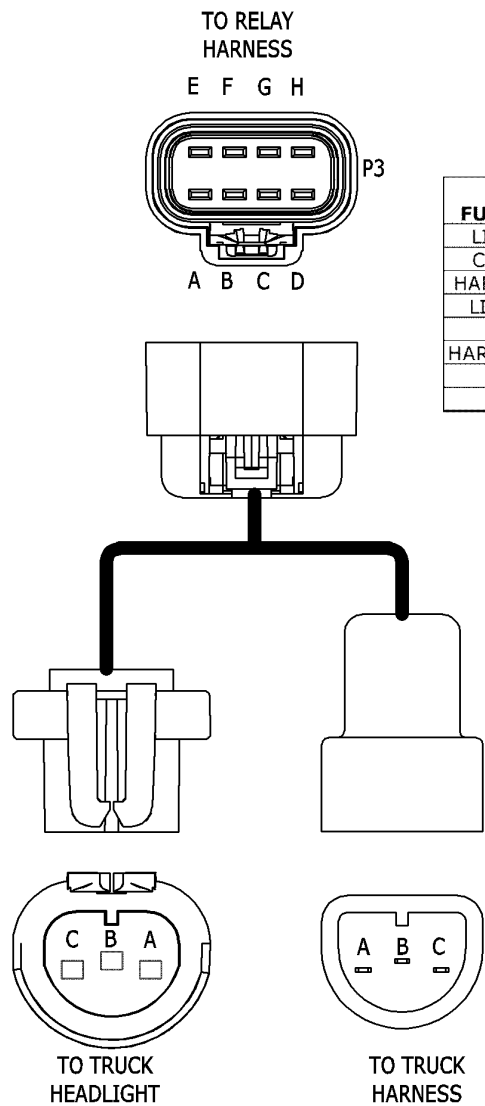

FUNCTION	P1 PIN	P2 PIN	P3 PIN	WIRE COLOR	RELAY HARNESS
LIGHT LB	B		A	BLK	YEL/BLK
COMMON	A	A	B	YEL/BLK	GRAY*
HARNESS LB		B	C	BLK	YEL/WHT
LIGHT HB	C		D	GRN/BLK	GRN/BLK
-			E	-	-
HARNESS HB	C	C	F	GRN	GRN/WHT
PARK			G	BROWN	BROWN
TURN			H	PURPLE	PURPLE

\* ONLY PRESENT ON SHORT RELAY HARNESS LEAD

16071140  
HB2/2B/2D

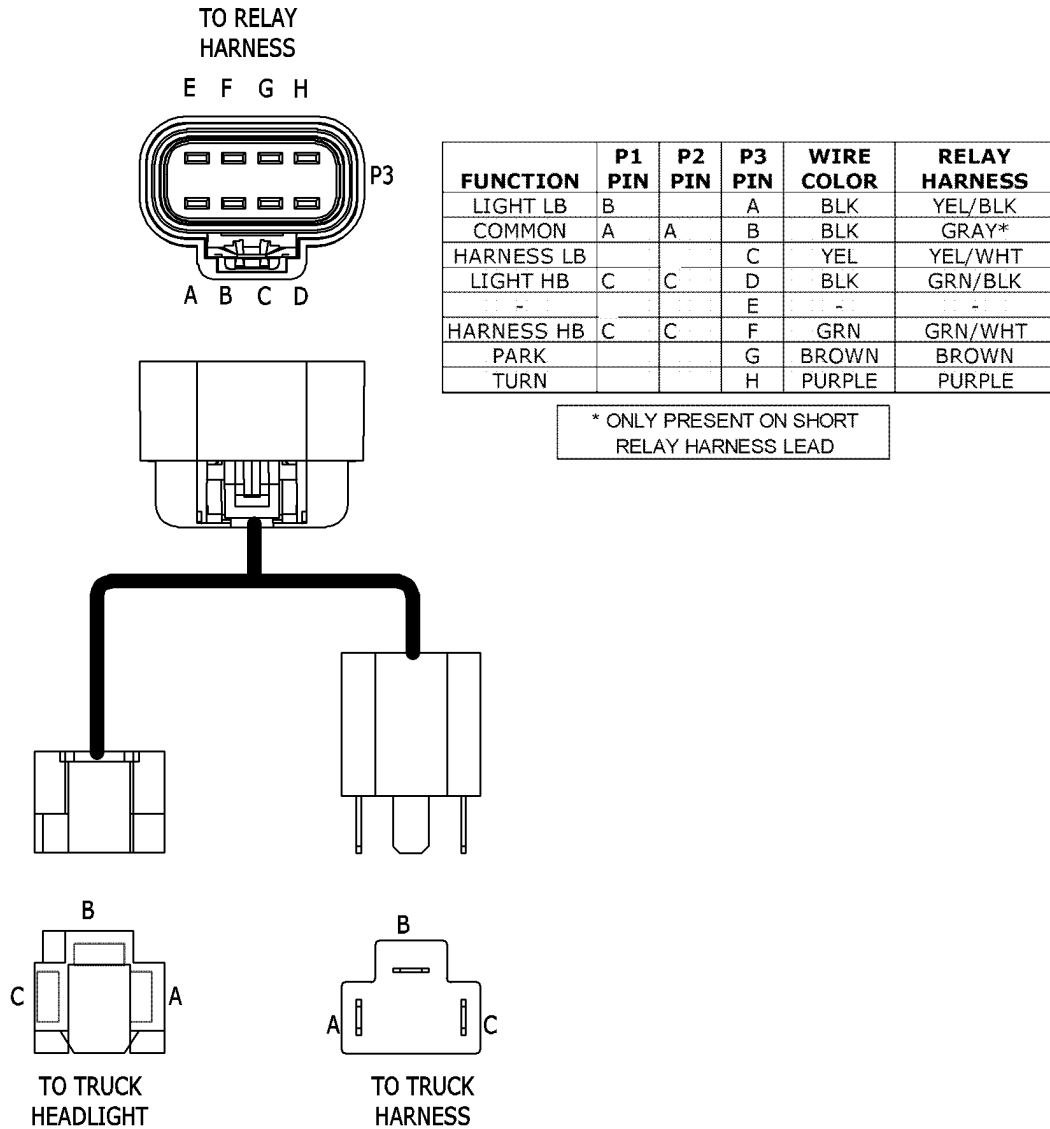

16071150  
HB3/HB4

TO RELAY  
HARNES

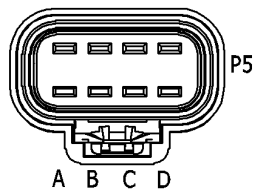

FUNCTION	P1 PIN	P2 PIN	P3 PIN	P4 PIN	P5 PIN	WIRE COLOR	RELAY HARNES
LIGHT LB	A				A	YEL	YEL/BLK
COMMON	B	B	B	B	B	BLACK	GRAY*
HARNES LB			A		C	YEL/BLK	YEL/WHT
LIGHT HB		A			D	GRN	GRN/BLK
-					E	-	-
HARNES HB				A	F	GRN/BLK	GRN/WHT
PARK					G	BROWN	BROWN
TURN					H	PURPLE	PURPLE

\* ONLY PRESENT ON SHORT  
RELAY HARNES LEAD

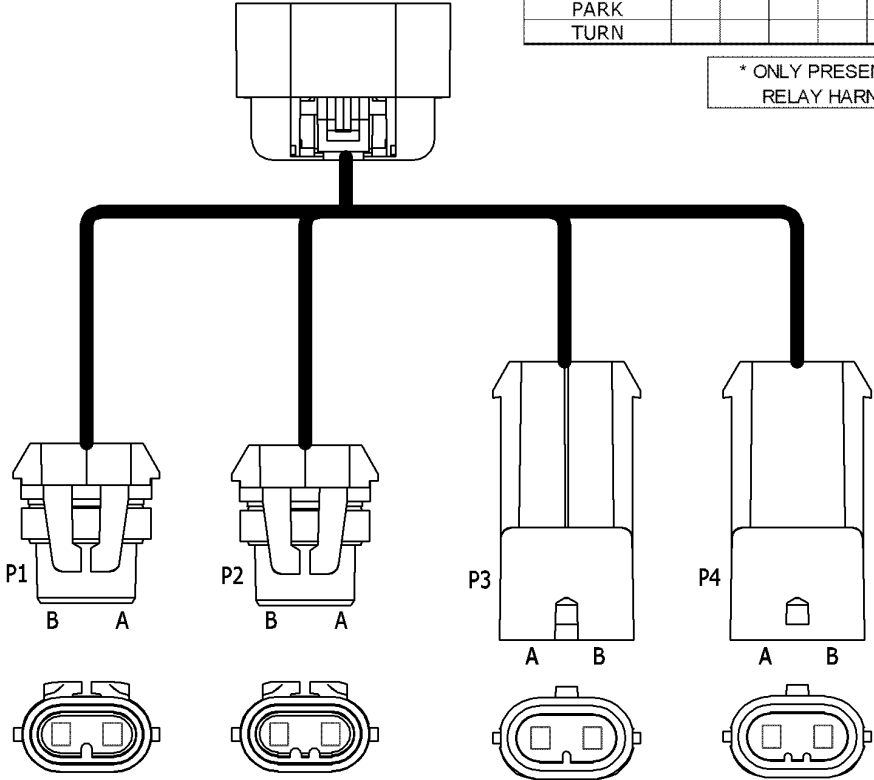

### 16071150R HB3/HB4 SWITCHED GROUND

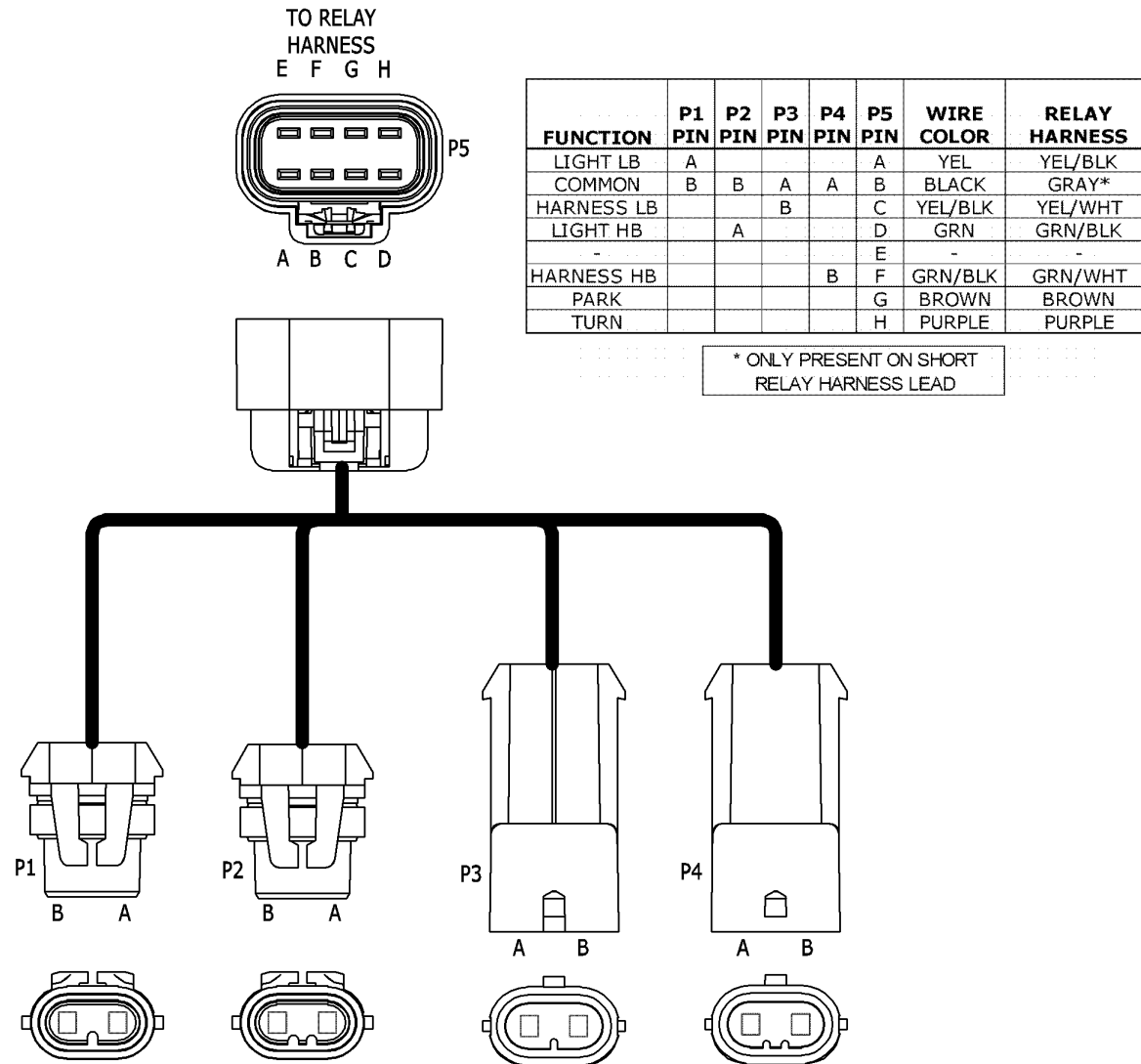

16071160  
HB3/H11

